

Product Features

- ✧ DFB laser transmitter and APD photo-detector
- ✧ Dual Data-rate of 1.25Gbps/1.0625Gbps Operation
- ✧ Up to 120KM transmission distance on 9/125μm SMF
- ✧ Compliant with SFP MSA and SFF-8472 with duplex LC receptacle
- ✧ Digital Diagnostic Monitor Interface
- ✧ Very low EMI and excellent ESD protection
- ✧ +3.3V single power supply
- ✧ Compatible with RoHS
- ✧ Operating case temperature Commercial: 0°C to +70°C
- ✧ Extended: -10°C to +80°C
- ✧ Industrial: -40°C to +85°C



Applications

- ✧ Gigabit Ethernet
- ✧ Fiber Channel
- ✧ Switch to Switch interface
- ✧ Switched backplane applications
- ✧ Router/Server interface
- ✧ Other optical transmission systems

Ordering Information

Part Number	Output Power	Rec. Sens	Data Rate	Wavelength	Distance
<i>FH-S5512CDL120</i>	-1 ~+6 db	-32db	1.25/1.0625Gbps	1550nm	120KM
<i>FH-S5512EDL120</i>					
<i>FH-S5512IDL120</i>					

General

FH-S5512CDL120 SFP transceivers are high performance, cost effective modules supporting data-rate of 1.25Gbps and 120km transmission distance with SMF

The transceiver consists of three sections: a DFB laser transmitter, a APD photodiode integrated with a trans-impedance Preamplifier (TIA) and MCU control unit. All modules satisfy class I laser safety requirements. The transceivers are compatible with SFP Multi-Source Agreement (MSA) and SFF-8472. For further information, please refer to SFP MSA.

Absolute Maximum Ratings

Parameter	Symbol	Min.	Max.	Unit	Note
Supply Voltage	Vcc	-0.5	3.6	V	
Storage Temperature		-40	85	°C	
Relative Humidity		5	85	%	

Note: Stress in excess of the maximum absolute ratings can cause permanent damage to the module

General Operating Characteristics

Parameter	Symbol	Min.	Typ.	Max.	Unit	Notes
Data Rate	Gigabit Ethernet		1.25		Gb/s	
	Fiber Channel		1.0625			
Supply Voltage	Vcc	3.1	3.3	3.5	V	
Supply Current	Icc			300	mA	
Operating Case Temperature	Tc	0		70	°C	
		-10		80		
		-45		85		

Electrical Input/Output Characteristics

Parameter	Symbol	Min.	Typical	Max.	Unit	Notes
Transmitter						
Diff. Input Voltage Swing		300		1800	mVpp	1
Tx Disable Input	H	V_{IH}	2.0	$V_{CC}+0.3$	V	
	L	V_{IL}	0	0.8		
Tx Fault Output	H	V_{OH}	2.0	$V_{CC}+0.3$	V	2
	L	V_{OL}	0	0.8		
Input Diff. Impedance	Z_{in}		100		Ω	
Receiver						
Diff. Output Voltage Swing		400		1000	mVpp	3
Rx LOS Output	H	V_{OH}	2.0	$V_{CC}+0.3$	V	2
	L	V_{OL}	0	0.8		

Note: 1) TD+/- are internally AC coupled with 100 Ω differential termination inside the module.

2) Tx Fault and Rx LOS are open collector outputs, which should be pulled up with 4.7k to 10k Ω resistors on the host board. Pull up voltage between 2.0V and $V_{CC}+0.3V$.

3) RD+/- outputs are internally AC coupled, and should be terminated with 100 Ω (differential) at the user SERDES.

Optical Characteristics

Parameter	Symbol	Min.	Typical	Max.	Unit	Notes
Transmitter						
Ave. Output Power (Enable)	Po	-1		+6	dBm	1
Extinction Ratio	ER	9			dB	1
Total Jitter	1.25G			0.431	UI	
Rise/Fall Time (20%-80%)	Tr-Tf			0.26	ns	2
Wavelength Range		1530	1550	1570	nm	
Spectral Width (RMS)				1	nm	
Output Optical Eye	Compliant with IEEE802.3 z (class 1 user safety)					
Receiver						
Operating Wavelength		1270		1610	nm	
Sensitivity	Pimin			-32	dBm	3
Min. Overload	Pimax	-3			dBm	3
Total Jitter	1.25G			0.749	UI	
LOS Assert	Pa	-40			dBm	
LOS De-assert	Pd			-33	dBm	
LOS Hysteresis	Pd-Pa	0.5		6	dB	

Note 1) Measured at 1250 Mb/s with PRBS 223 – 1 NRZ test pattern.

2) Unfiltered, measured with a PRBS 223-1 test pattern @1.25Gbps

3) Measured at 1250 Mb/s with PRBS 223 – 1 NRZ test pattern for BER < 1x10⁻¹²

Pin Definitions And Functions

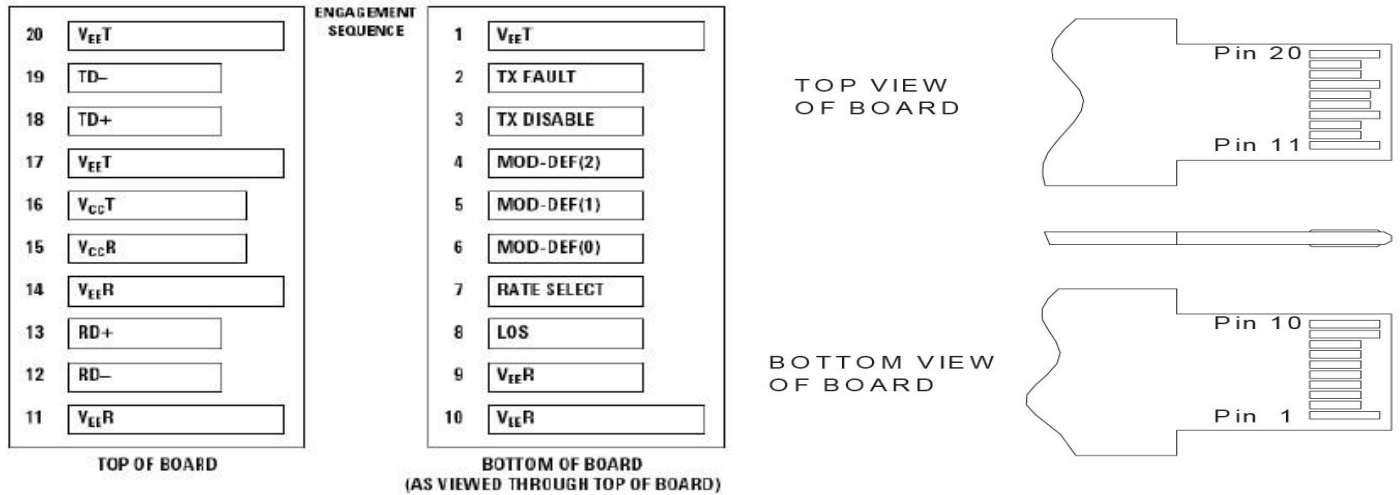

PIN #	Name	Function	Notes
1	V _{ee} T	Tx ground	
2	Tx Fault	Tx fault indication, Open Collector Output, active “H”	Note 1
3	Tx Disable	LVTTL Input, internal pull-up, Tx disabled on “H”	Note 2
4	MOD-DEF2	2 wire serial interface data input/output (SDA)	Note 3
5	MOD-DEF1	2 wire serial interface clock input (SCL)	Note 3
6	MOD-DEF0	Model present indication	Note 3
7	Rate select	No connection	
8	LOS	Rx loss of signal, Open Collector Output, active “H”	Note 4
9	V _{ee} R	Rx ground	
10	V _{ee} R	Rx ground	
11	V _{ee} R	Rx ground	
12	RD-	Inverse received data out	Note 5
13	RD+	Received data out	Note 5
14	V _{ee} R	Rx ground	
15	V _{cc} R	Rx power supply	
16	V _{cc} T	Tx power supply	
17	V _{ee} T	Tx ground	
18	TD+	Transmit data in	Note 6
19	TD-	Inverse transmit data in	Note 6
20	V _{ee} T	Tx ground	

Note 1) When high, this output indicates a laser fault of some kind. Low indicates normal operation. And should be pulled up with a 4.7 – 10KΩ resistor on the host board.

Note 2) TX disable is an input that is used to shut down the transmitter optical output. It is pulled up within the module with a 4.7 – 10KΩ resistor. Its states are:

Low (0 – 0.8V): Transmitter on ($>0.8, < 2.0V$): Undefined
High (2.0V~Vcc+0.3V): Transmitter Disabled Open: Transmitter Disabled

Note 3) Mod-Def 0,1,2. These are the module definition pins. They should be pulled up with a 4.7K – 10KΩ resistor on the host board. The pull-up voltage shall be between 2.0V~Vcc+0.3V.

Mod-Def 0 has been grounded by the module to indicate that the module is present

Mod-Def 1 is the clock line of two wire serial interface for serial ID

Mod-Def 2 is the data line of two wire serial interface for serial ID

Note 4) When high, this output indicates loss of signal (LOS). Low indicates normal operation.

Note 5) RD+/-: These are the differential receiver outputs. They are AC coupled 100Ω differential lines which should be terminated with 100Ω (differential) at the user SERDES. The AC coupling is done inside the module and is thus not required on the host board.

Note 6) TD+/-: These are the differential transmitter inputs. They are AC-coupled, differential lines with 100Ω differential termination inside the module. The AC coupling is done inside the module and is thus not required on the host board.

Functional Diagram

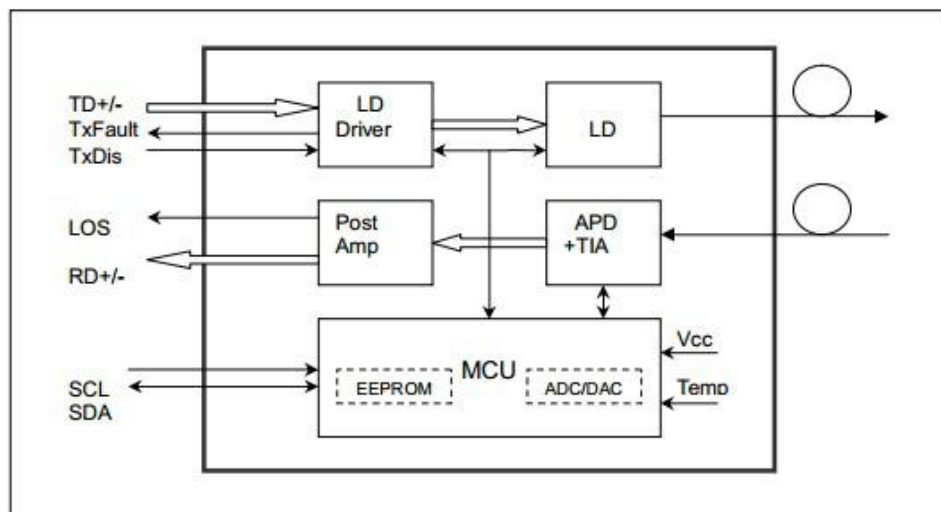

Typical Interface Circuit

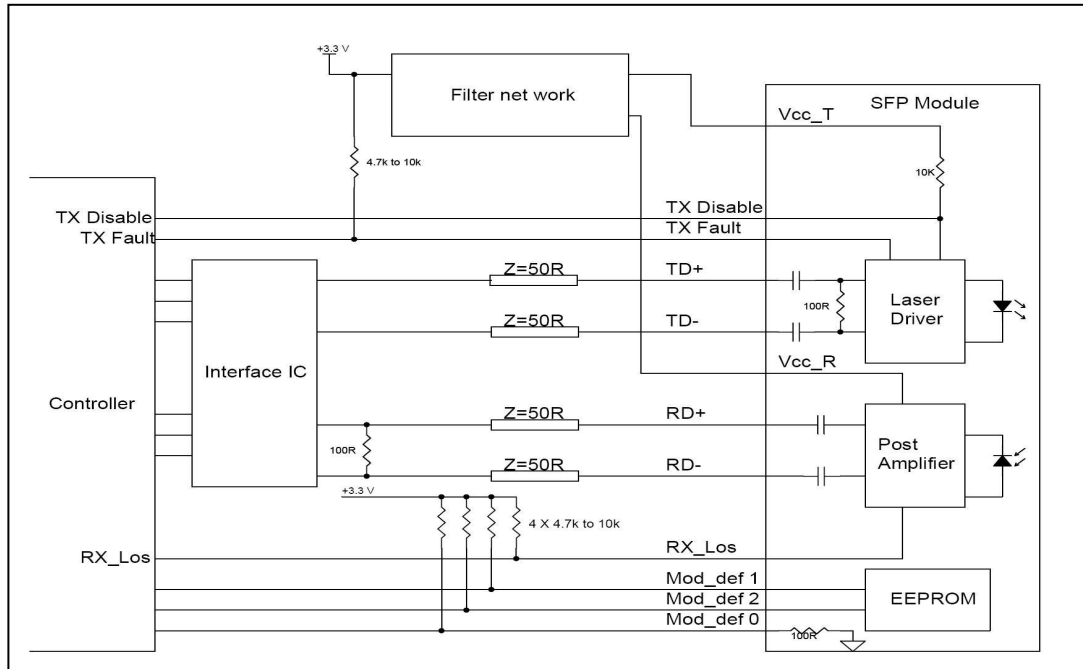

Package Dimensions

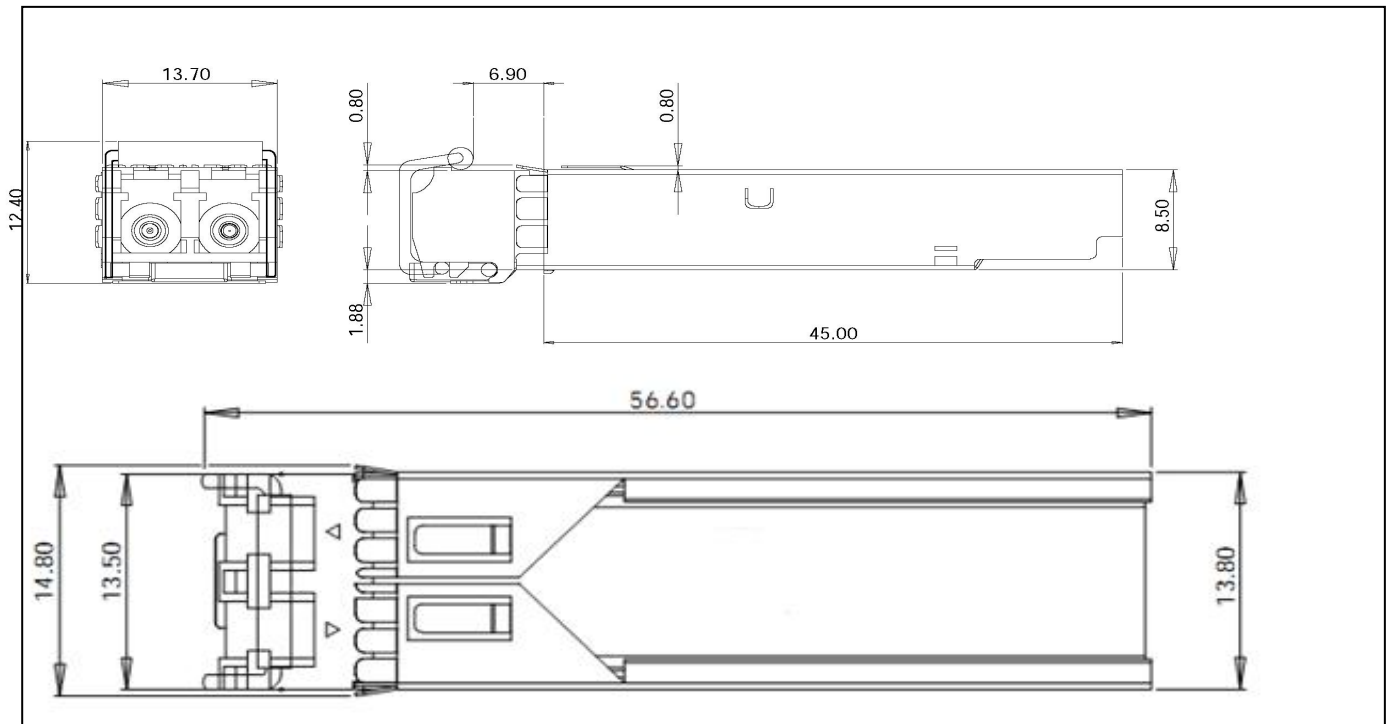



FH-S5512CDL120
1.25G SFP 1550nm LC 120km DDMI

For More Information

FANG HANG TECH LIMITED

Add: Room 908, Jingyuan Building, 28 Bulong Rd, Longgang District, Shenzhen China

Tel: +86-755-89584520

Fax: +86-755-89584520

sales@fanghangtech.com

www.fanghangtech.com