

Product Features

- ✧ Support 10Gbase-T / 5Gbase-T / 2.5Gbase-T / 1000base-T
- ✧ Hot-pluggable SFP footprint
- ✧ Compact RJ-45 connector assembly
- ✧ RoHS compliant and lead-free
- ✧ Single +3.3V power supply
- ✧ 10 Gigabit Ethernet over Cat 6a cable
- ✧ Ambient Operating temperature: 0°C to +65°C

Ordering Information

Part Number	Cable	Reach	Host Port
10Gbase-T	CAT6A	30m	XFI
5Gbase-T/2.5Gbase-t	CAT5E	50m	5GBase-R/2.5GBase-X
1000base-T	CAT5E	100m	1000base-FX

Product Description

SFP+-10GBASE-T Copper Small Form Pluggable (SFP) transceivers are based on the SFP Multi Source Agreement (MSA) . They are compatible with the 10Gbase-T / 5Gbase-T / 2.5Gbase-T / 1000base-T standards as specified in IEEE Std 802.3 . SFP+-10GBASE-T uses the SFP's RX_LOS pin for link indication. If pull up SFP's TX_DISABLE pin, PHY IC be reset.

SFP to Host Connector Pin Out

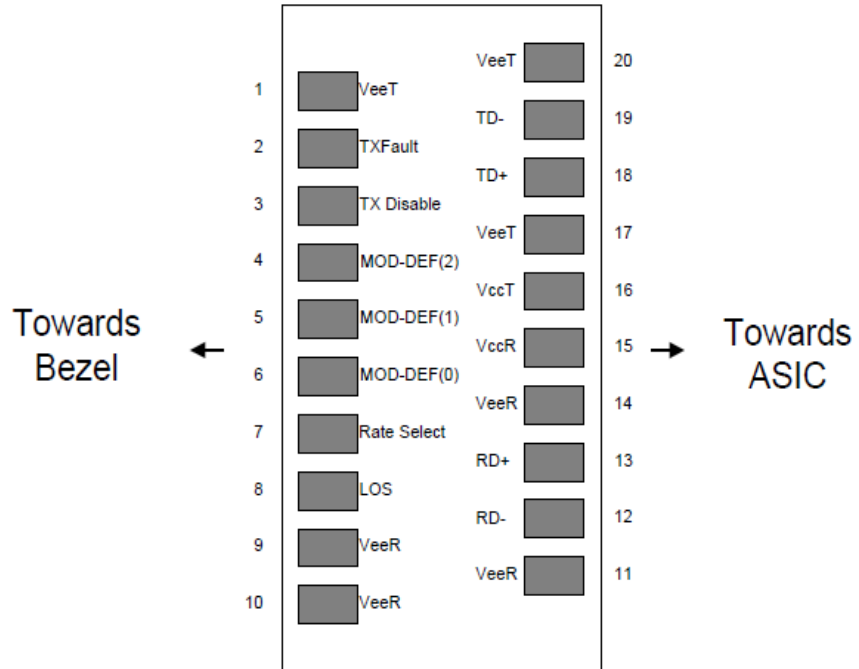

Pin	Symbol	Name/Description	Ref.
1	VEET	Transmitter Ground (Common with Receiver Ground)	1
2	TFAULT	Transmitter Fault. Not supported.	
3	TDIS	Transmitter Disable. Laser output disabled on high or open.	2
4	MOD_DEF(2)	Module Definition 2. Data line for Serial ID.	3
5	MOD_DEF(1)	Module Definition 1. Clock line for Serial ID.	3
6	MOD_DEF(0)	Module Definition 0. Grounded within the module.	3
7	Rate Select	No connection required	
8	LOS	High indicates no linked. low indicates linked.	4
9	VEER	Receiver Ground (Common with Transmitter Ground)	1
10	VEER	Receiver Ground (Common with Transmitter Ground)	1
11	VEER	Receiver Ground (Common with Transmitter Ground)	1
12	RD-	Receiver Inverted DATA out. AC Coupled	
13	RD+	Receiver Non-inverted DATA out. AC Coupled	

14	VEER	Receiver Ground (Common with Transmitter Ground)	1
15	VCCR	Receiver Power Supply	
16	VCCT	Transmitter Power Supply	
17	VEET	Transmitter Ground (Common with Receiver Ground)	1
18	TD+	Transmitter Non-Inverted DATA in. AC Coupled.	
19	TD-	Transmitter Inverted DATA in. AC Coupled.	
20	VEET	Transmitter Ground (Common with Receiver Ground)	1

Notes:

1. Circuit ground is connected to chassis ground
2. PHY disabled on $T_{DIS} > 2.0V$ or open, enabled on $T_{DIS} < 0.8V$
3. Should be pulled up with 4.7k - 10k Ohms on host board to a voltage between 2.0 V and 3.6 V. MOD_DEF(0) pulls line low to indicate module is plugged in.
4. LVTTTL compatible with a maximum voltage of 2.5V.

+3.3V Volt Electrical Power Interface

The SFP+-10GBASE-T has an input voltage range of 3.3 V +/- 5%. The 4V maximum voltage is not allowed for continuous operation.

Parameter	Symbol	Min	Typ	Max	unit	Notes/Conditions
Supply Current	Is		700	900	mA	3.0W max power over full range of voltage and temperature. See caution note below
Input Voltage	Vcc	3.13	3.3	3.47	V	Referenced to GND
Maximum Voltage	Vmax			4	V	
Surge Current	Isurge		TBD		mA	Hot plug above steady state current. See caution note below

Caution: Power consumption and surge current are higher than the specified values in the SFP MSA

Low-Speed Signals

MOD_DEF(1) (SCL) and MOD_DEF(2) (SDA), are open drain CMOS signals (see section VII, "Serial Communication Protocol"). Both MOD_DEF(1) and MOD_DEF(2) must be pulled up to host_Vcc

Low-Speed Signals, Electronic Characteristics						
Parameter	Symbol	Min	Max	unit	Notes/Conditions	
SFP Output LOW	VOL	0	0.5	V	4.7k to 10k pull-up to host_Vcc, measured at host side of connector	
SFP Output HIGH	VOH	host_Vcc -0.5	host_Vcc + 0.3	V	4.7k to 10k pull-up to host_Vcc, measured at host side of connector	
SFP Input LOW	VIL	0	0.8	V	4.7k to 10k pull-up to Vcc, measured at SFP side of connector	
SFP Input HIGH	VIH	2	Vcc + 0.3	V	4.7k to 10k pull-up to Vcc, measured at SFP side of connector	

High-Speed Electrical Interface

All high-speed signals are AC-coupled internally

High-Speed Electrical Interface, Transmission Line-SFP						
Parameter	Symbol	Min	Typ	Max	unit	Notes/Conditions
Line Frequency	fL		125		MHz	5-level encoding, per IEEE 802.3
Tx Output Impedance	Zout,TX		100		Ohm	Differential, for all frequencies between 1MHz and 125MHz
Rx Input Impedance	Zin,RX		100		Ohm	Differential, for all frequencies between 1MHz and 125MHz
High-Speed Electrical Interface, Host-SFP						
Parameter	Symbol	Min	Typ	Max	unit	Notes/Conditions
Single ended data input swing	Vinsing	250		1200	mV	Single ended
Single ended data output swing	Voutsing	350		800	mV	Single ended
Rise/Fall Time	T _r ,T _f		175		psec	20%-80%
Tx Input Impedance	Zin		50		Ohm	Single ended
Rx Output Impedance	Zout		50		Ohm	Single ended

Environmental Specifications

Automatic crossover detection is enabled. External crossover cable is not required

Parameter	Symbol	Min	Typ	Max	unit	Notes/Conditions
Operating Temperature	Top	0		65	°C	Case temperature
Storage Temperature	Tsto	-40		85	°C	Ambient temperature

Serial Communication Protocol

SFPs support the 2-wire serial communication protocol outlined in the SFP MSA. These SFPs use an MCU, can be accessed with address of A0h

Parameter	Symbol	Min	Typ	Max	unit	Notes/Conditions
I ² C Clock Rate		0		200,000	Hz	

Package Dimensions

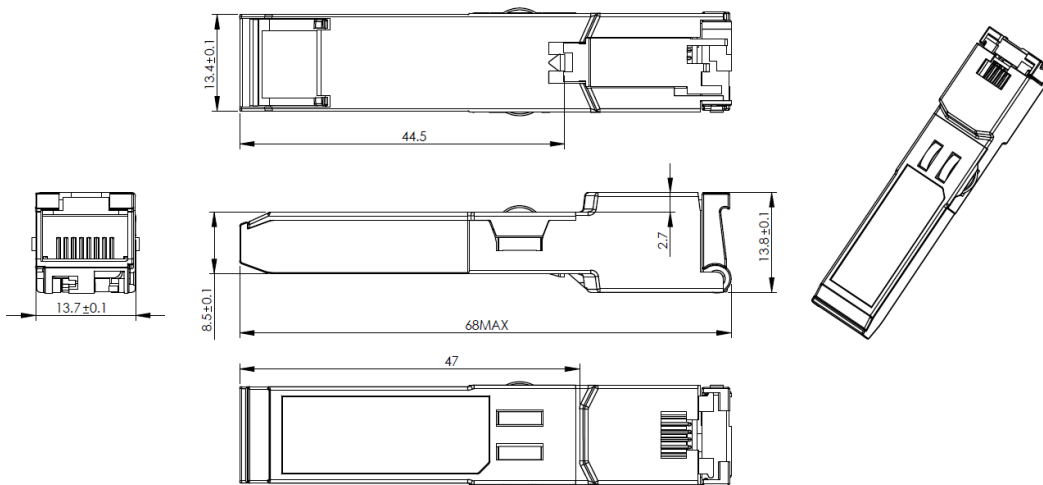

For More Information

FANG HANG TECH LIMITED

Add : 908 Room, Jingyuan Building, 28 Bulong Rd, Longgang District, Shenzhen. China

Tel: +86-755-89584520

Fax: +86-755-89584520

sales@fanghangtech.com

www.fanghangtech.com