



Product Features

- ◇ 4 CWDM lanes MUX/DEMUX design
- ◇ 4 independent full-duplex channels Up to 11.2Gbps data rate per wavelength
- ◇ 4 CWDM channels are 1271, 1291, 1311 and 1331 nm
- ◇ Up to 10km transmission
- ◇ Single +3.3V power supply
- ◇ Maximum 3.5W operation power
- ◇ Operating case temperature: 0~70C

Applications

- ◇ 40G Ethernet
- ◇ Infiniband 4X SDR DDR QDR
- ◇ 40G TELECOM connections
- ◇ Compliant with IEEE802.3ba
- ◇ Compliant with QSFP+ MSA: SFF-8436
- ◇ RoHS compliant

Ordering Information

Part Number	Output Power	Rec. Sens	Data Rate	Wavelength	Distance
<i>FH-QSFP4TCDL10</i>	-7 ~ +2.5db	-11db	40G	1270/1290/1310/1330nm	10KM

General

FH-QSFP4TCDL10 Stresses in excess of the absolute maximum ratings can cause permanent damage to the device. These are absolute stress ratings only. Functional operation of the device is not implied at these or any other conditions in excess of those given in the operational sections of the data sheet. Exposure to absolute maximum ratings will cause permanent damage and/or adversely affect device reliability.

Absolute Maximum Ratings

Parameter	Symbol	Min	Max	Unit	Note
Storage Temperature	TS	-40	85	°C	
Relative Humidity	RH	0	85	%	
Supply Voltage	Vcc	-0.5	4.0	V	

Recommended Operating Conditions

Parameter	Symbol	Min	Typ	Max	Unit	Note.
Power Supply Voltage	Vcc	3.13	3.30	3.47	V	
Power Supply Current	Icc	-	-	1000	mA	
Case Operating Temperature	Tc	-5	-	+70	°C	

**Electrical Input/Output Characteristics**

Parameter	Symbol	Min.	Typical	Max	Unit	Notes
Power Consumption (XLPP1)		-		3.5	W	
Supply Current	ICC		0.75	1.0	A	
Control I/O Voltage, High	VIH	2.0		VCC	V	
Control I/O Voltage, Low	VIL	0		0.7	V	
Inter-Channel Skew	TSK			150	ps	
RESETL Duration		2	10		us	
RESETL De-assert time				2000	ms	
Power on time				2000	ms	
Transmitter (XLPP1)						
Single Ended Output Voltage Tolerance		-0.3	-	4	V	Referred to signal common
AC Common mode Voltage Tolerance (RMS)		15	-	-	mV	
Tx Input Diff Voltage	VI	100		1000	mV	
Tx Input Diff Impedance	ZIN	80	100	120	Ω	
Differential Input Return Loss		See IEEE 802.3ba 86A.4.11			dB	10MHz-11.1GHz
J2 Jitter Tolerance	Jt2			0.18	UI	
J9 Jitter Tolerance	Jt9			0.26	UI	
Data Dependent Pulse Width Shrinkage	DDPWS			0.07	UI	
Eye Mask Coordinates {X1, X2 , Y1, Y2}		0.1 , 0.31 95 , 350			UI mV	



Parameter	Symbol	Min.	Typical	Max	Unit	Notes
Receiver (XLPP1)						
Single Ended Output Voltage Tolerance ¹		-0.3	-	4	V	Referred to TP1 signal common
AC Common mode Voltage Tolerance (RMS)		-	-	7.5	mV	
Termination Mismatch at 1MHz				5	%	
Differential Output Return Loss		See IEEE 802.3ba 86A.4.2.1			dB	10MHz-11.1GHz
Common-mode Output Return Loss		See IEEE 802.3ba 86A.4.2.2			dB	10MHz-11.1GHz
Rx Output Diff Voltage	Vo		600	800	mV	
Rx Output Rise and Fall Time	Tr/Tf			35	ps	20% to 80%
J2 Jitter Tolerance	Jr2			0.46	UI	
J9 Jitter Tolerance	Jr9			0.63	UI	
Eye Mask Coordinates {X1, X2 , Y1, Y2}		0.29 , 0.5 150 , 425			UI mV	

Notes: [1]The single ended input voltage tolerance is the allowable range of the instantaneous input signals

Optical Characteristics

Parameter	Symbol	Min.	Typical	Max.	Unit	Notes
Wavelength Assignment	L0	1264.5	1271	1277.5	nm	
	L1	1284.5	1291	1297.5	nm	
	L2	1304.5	1311	1317.5	nm	
	L3	1324.5	1331	1337.5	nm	
Transmitter						
Side-mode Suppression Ratio	SMSR	30	-	-	dB	
Total Average Launch Power	P _T	-	-	8.3	dBm	
Average Launch Power, each Lane		-7	-	2.3	dBm	
Optical Modulation Amplitude, each Lane	OMA	-4	-	+3.5	dBm	
Difference in Launch Power between any two Lanes (OMA)		-	-	6.5	dB	
Launch Power in OMA minus Transmitter and Dispersion Penalty (TDP), each Lane		-4.8	-		dBm	
TDP, each Lane	TDP			2.3	dB	
Extinction Ratio	ER	3.5	-	-	dB	
Relative Intensity Noise	R _{in}	-	-	-128	dB/Hz	12dB reflection
Optical Return Loss Tolerance		-	-	20	dB	
Transmitter Reflectance	R _T			-12	dB	



Transmitter Eye Mask Definition {X1, X2, X3, Y1, Y2, Y3}		{0.25,0.4, 0.45,0.25, 0.28,0.4}				
Average Launch Power OFF Transmitter, each Lane	P _{off}			-30	dBm	
Receiver						
Damage Threshold	TH _d	3.3			dBm	1
Average Power at Receiver Input, each Lane		-13.7		2.3	dBm	
Receiver Reflectance	R _R	-	-	-26	dB	
Receiver Power (OMA), each Lane		-	-	3.5	dBm	
Stressed Receiver Sensitivity in OMA, each Lane		-	-	-9.9	dBm	
Receiver Sensitivity, each Lane	S _R	-	-	-11.5	dBm	
Difference in Receive Power between any two Lanes (OMA)				7.5	dB	
Conditions of Stress Receiver Sensitivity Test²						
Vertical Eye Closure Penalty, each Lane			1.6		dB	
Stressed Eye Jitter, each Lane			0.3		UI	

Notes:

[1] The receiver shall be able to tolerate, without damage, continuous exposure to a modulated optical input signal having this power level on one lane. The receiver does not have to operate correctly at this input power.

[2] Vertical eye closure penalty and stressed eye jitter are test conditions for measuring stressed receiver sensitivity. They are not characteristics of the receiver.

Pin Definitions And Functions

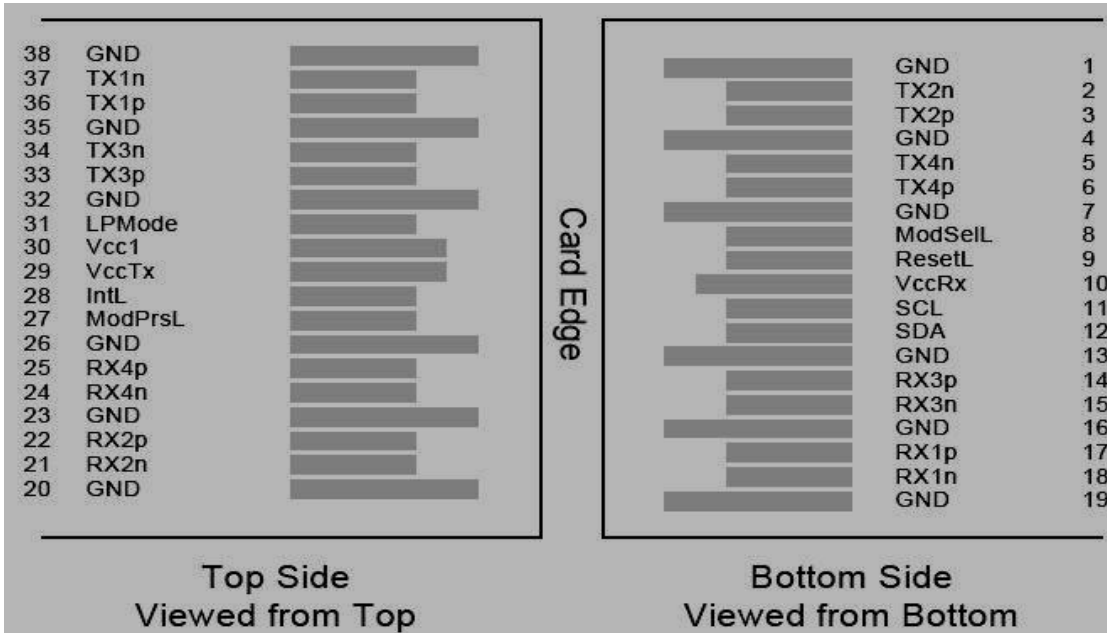

Pin	Logic	Symbol	Name/Description	Note
1		GND	Ground	1
2	CML-I	Tx2n	Transmitter Inverted Data Input	
3	CML-I	Tx2p	Transmitter Non-Inverted Data output	
4		GND	Ground	1
5	CML-I	Tx4n	Transmitter Inverted Data Input	
6	CML-I	Tx4p	Transmitter Non-Inverted Data output	
7		GND	Ground	1
8	LVTLL-I	ModSelL	Module Select	
9	LVTLL-I	ResetL	Module Reset	
10		VccRx	+ 3.3V Power Supply Receiver	2
11	LVC MOS-I/O	SCL	2-Wire Serial Interface Clock	
12	LVC MOS-I/O	SDA	2-Wire Serial Interface Data	
13		GND	Ground	



14	CML-O	Rx3p	Receiver Non-Inverted Data Output	
15	CML-O	Rx3n	Receiver Inverted Data Output	
16		GND	Ground	1
17	CML-O	Rx1p	Receiver Non-Inverted Data Output	
18	CML-O	Rx1n	Receiver Inverted Data Output	
19		GND	Ground	1
20		GND	Ground	1
21	CML-O	Rx2n	Receiver Inverted Data Output	
22	CML-O	Rx2p	Receiver Non-Inverted Data Output	
23		GND	Ground	1
24	CML-O	Rx4n	Receiver Inverted Data Output	1
25	CML-O	Rx4p	Receiver Non-Inverted Data Output	
26		GND	Ground	1
27	LVTTL-O	ModPrsL	Module Present	
28	LVTTL-O	IntL	Interrupt	
29		VccTx	+3.3 V Power Supply transmitter	2
30		Vcc1	+3.3 V Power Supply	2
31	LVTTL-I	LPMODE	Low Power Mode	
32		GND	Ground	1
33	CML-I	Tx3p	Transmitter Non-Inverted Data Input	
34	CML-I	Tx3n	Transmitter Inverted Data Output	
35		GND	Ground	1
36	CML-I	Tx1p	Transmitter Non-Inverted Data Input	
37	CML-I	Tx1n	Transmitter Inverted Data Output	
38		GND	Ground	1

Notes:

[1] GND is the symbol for signal and supply (power), Connect these directly to the host board signal common ground plane

[2] VccRx, Vcc1 and VccTx are the receiving and transmission power suppliers and shall be applied concurrently. Vcc Rx, Vcc1 and Vcc Tx may be internally connected within the QSFP+, The connector pins are each rated for a maximum current of 500mA.

Digital Diagnostic Functions

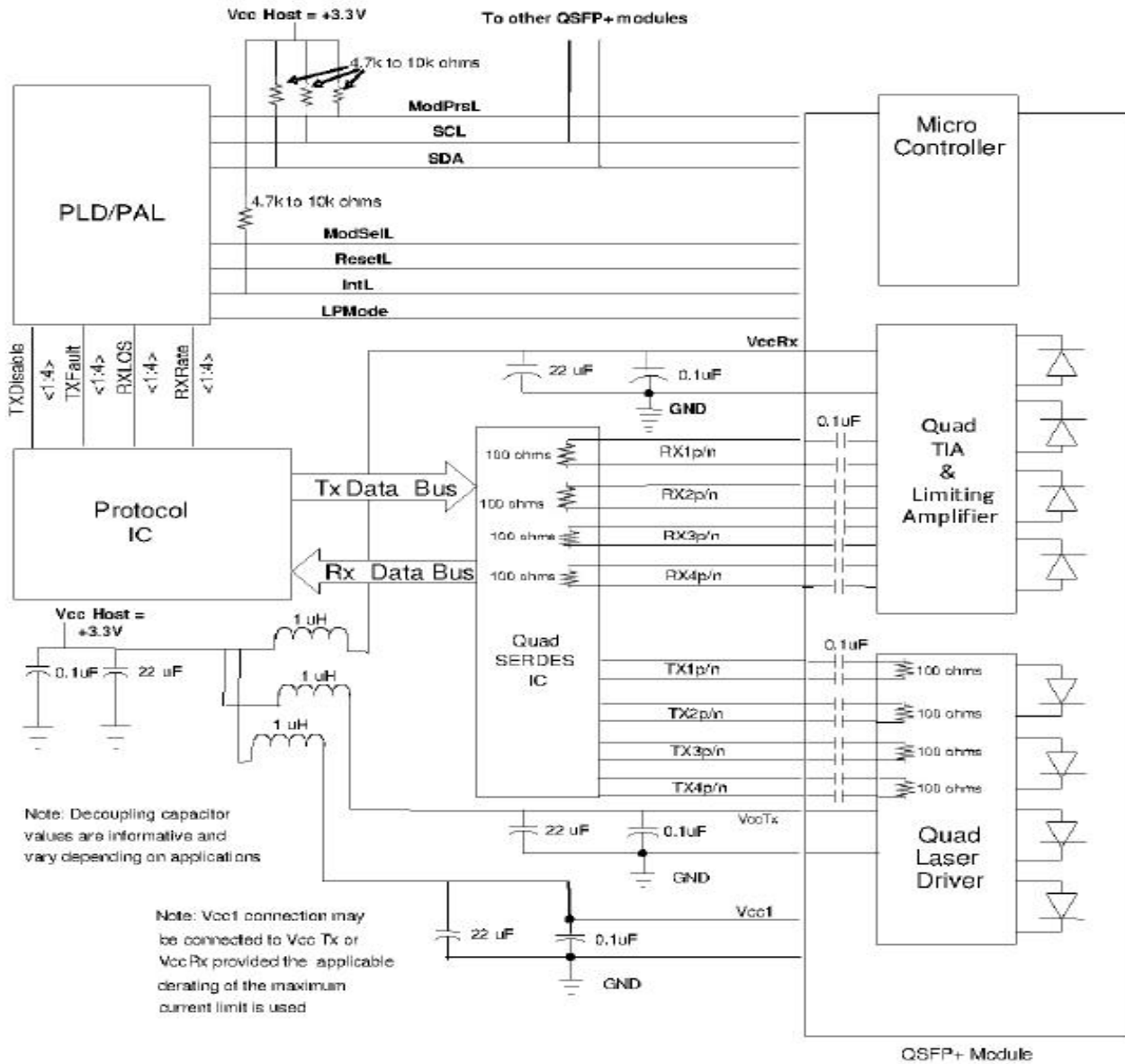



Package Dimensions

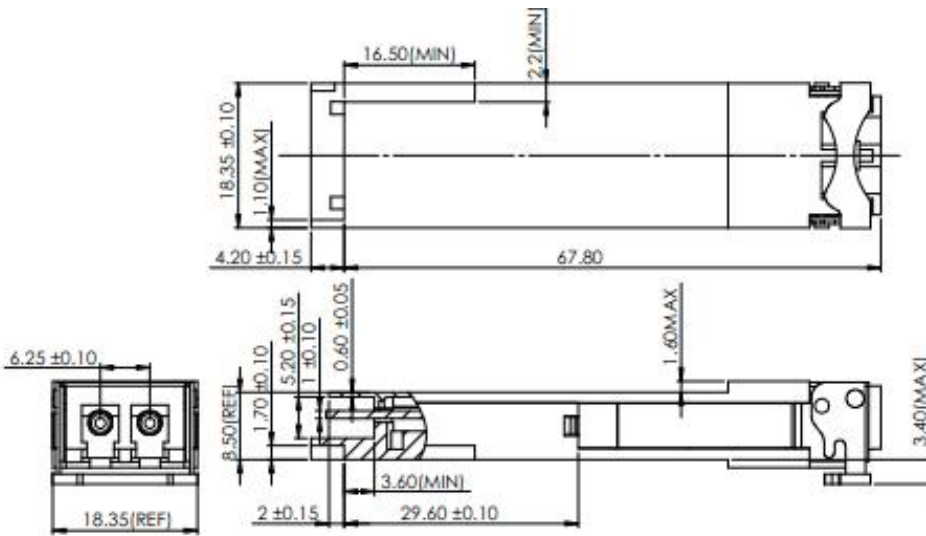

For More Information

FANG HANG TECH LIMITED

Add : 908 Room, Jingyuan Building, 28 Bulong Rd, Longgang District, Shenzhen. China

Tel: +86-755-89584520

Fax: +86-755-89584520

sales@fanghangtech.com

www.fanghangtech.com