

## Product Features

- ✧ 4 channels full-duplex transceiver modules
- ✧ Transmission data rate up to 10.5Gbps per channel
- ✧ 4 channels 850nm VCSEL array
- ✧ 4 channels PIN photo detector array
- ✧ Low power consumption <1.5W
- ✧ Hot Pluggable QSFP form factor
- ✧ Maximum link length of 300m on OM3 Multimode Fiber (MMF) and 150m on OM4 MMF
- ✧ Single MPO connector receptacle
- ✧ Built-in digital diagnostic functions
- ✧ Operating case temperature 0°C to +70°C
- ✧ 3.3V power supply voltage
- ✧ RoHS 6 compliant

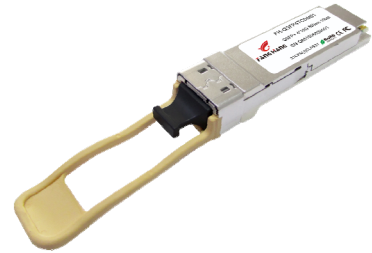

## Applications

- ✧ 40GBASE-SR4 40G Ethernet
- ✧ Datacom/Telecom switch & router connections
- ✧ Data Aggregation and Backplane Applications
- ✧ Proprietary Protocol and Density Applications
- ✧ Infiniband transmission at 4ch SDR, DDR and QDR

## Ordering Information

Part Number	Output Power	Rec. Sens	Data Rate	Wavelength	Distance
<i>FH-QSFP4TCDL01</i>	-7.6 ~ -2.4db	-5.4db	40G	850nm	100M

## General

FH-QSFP4TCDL01 IS Four-Channel, Pluggable, Parallel, Fiber-Optic QSFP+ Transceiver for 40 Gigabit Ethernet Applications. This transceiver is a high performance module for short-range multi-lane data communication and interconnect applications. It integrates four data lanes in each direction with 40 Gbps bandwidth. Each lane can operate at 10.3125Gbps up to 300m using OM3 fiber or 150m using OM4 fiber. These modules are designed to operate over multimode fiber systems using a nominal wavelength of 850nm. The electrical interface uses a 38 contact edge type connector. The optical interface uses an 12 fiber MTP (MPO) connector. This module incorporates Fanghang tech proven circuit and VCSEL technology to provide reliable long life, high performance, and consistent service.

## Absolute Maximum Ratings

Parameter	Min	Max	Units
Storage Temperature	-20	85	0C
Operating Case Temperature	-5	70	0C
Supply Voltage	3.1	3.5	V
Power consumption		1.5	W

## General Operating Characteristics

Parameter	Value	Unit	Notes
Module Form Factor	QSFP+		
Number of Lanes	4 Tx and 4 Rx		
Maximum Aggregate Data Rate	42.0	Gb/s	

Maximum Data Rate per Lane	10.5	Gb/s	Higher bit rates may be supported. Please contact Finisar.			
Protocols Supported	Typical applications include 40G Ethernet, Infiniband, Fibre Channel, SATA/SAS3					
Electrical Interface and Pin-out	38-pin edge connector		Pin-out as defined by the QSFP+ MSA			
Maximum Power Consumption per End	1.5	Watts	Varies with output voltage swing and pre-emphasis settings (see Figure 2)			
Management Interface	Serial, I2C-based, 400 kHz maximum frequency		As defined by the QSFP+ MSA			
Data Rate Specifications	Symbol	Min	Typ	Max	Units	Ref.
Bit Rate per Lane	BR	1062		10500	Mb/sec	1
Bit Error Ratio	BER			10-12		2
Link distance on OM3 MMF	d			100	meters	3
Link distance on OM4 MMF	d			150	meters	3

Notes:

1. Compliant with 40G Ethernet. Compatible with 1/10 Gigabit Ethernet and 1/2/4/8/10G Fibre Channel.
2. Tested with a PRBS 231-1 test pattern.
3. Per 40GBASE-SR4, IEEE 802.3ba

### Electrical Input/Output Characteristics

Parameter	Symbol	Min	Typical	Max	Unit	Notes
Transmitter						
Centre Wavelength	$\lambda_c$	840	850	860	nm	
RMS spectral width	$\Delta\lambda$			0.65	nm	
Average launch power, each lane	Pout	-7.5		2.5	dBm	

Difference in launch power between any two lanes (OMA)				4	dB	
Extinction Ratio	ER	3			dB	
Peak power, each lane				4	dBm	
Transmitter and dispersion penalty (TDP), each lane	TDP			3.5	dB	
Average launch power of OFF transmitter, each lane				-30	dB	
Eye Mask coordinates: X1, X2, X3, Y1, Y2, Y3	SPECIFICATION VALUES 0.23, 0.34, 0.43, 0.27, 0.35, 0.4					Hit Ratio = 5x10 <sup>-5</sup>
Receiver						
Centre Wavelength	$\lambda_c$	840	850	860	nm	
Stressed receiver sensitivity in OMA				-5.4	dBm	1
Maximum Average power at receiver, each lane				2.4	dBm	
Minimum Average power at receiver, each lane				-9.5	dBm	
Receiver Reflectance				-12	dB	
Peak power, each lane				4	dBm	
LOS Assert		-30			dBm	
LOS De-Assert – OMA				-7.5	dBm	
LOS Hysteresis		0.5			dB	

Note 1) Measured with conformance test signal at TP3 for BER = 10e<sup>-12</sup> Receiver Characteristics

## Optical Characteristics

Parameter	Symbol	Min.	Typical	Max.	Unit	Note
Transmitter						
Operating Wavelength			850		nm	
Ave. output power (Enabled)	P <sub>o</sub>	-6		-1	dBm	1
Extinction Ratio	ER	3.5			dB	1

RMS spectral width	$\Delta\lambda$			0.45	nm	
Rise/Fall time (20%~80%)	Tr/Tf			45	ps	2
Optical modulation amplitude	OMA			-2.8	dBm	
Dispersion penalty				3.9	dB	
Output Optical Eye	IEEE 802.3-2005 Compliant					
Receiver						
Operating Wavelength		840		860	nm	
Sensitivity	Psen			-11	dBm	3
Min. overload	Pimax	-1			dBm	
LOS Assert	Pa	-24			dBm	
LOS De-assert	Pd			-12	dBm	
LOS Hysteresis	Pd-Pa	0.5		4	dB	

Note 1) Measured at 10.3125b/s with PRBS 2<sup>31</sup> – 1 NRZ test pattern.

Note 2) 20%~80%

Note 3) Under the ER worst case, measured at 10.3125 Gb/s with PRBS 2<sup>31</sup> - 1 NRZ test pattern for BER < 1x10<sup>-12</sup>

## Pin Definitions And Functions

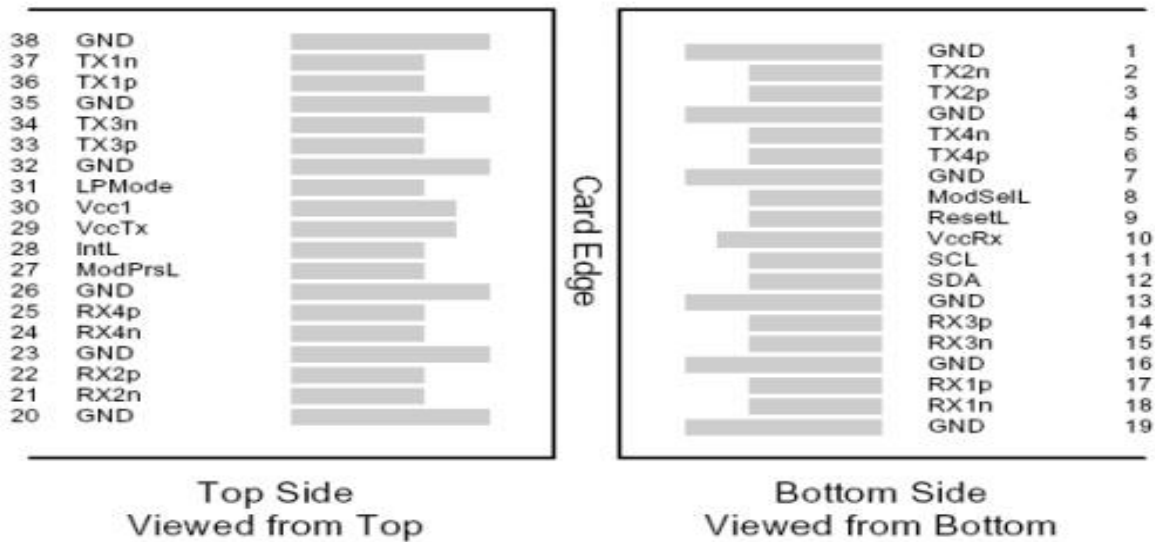
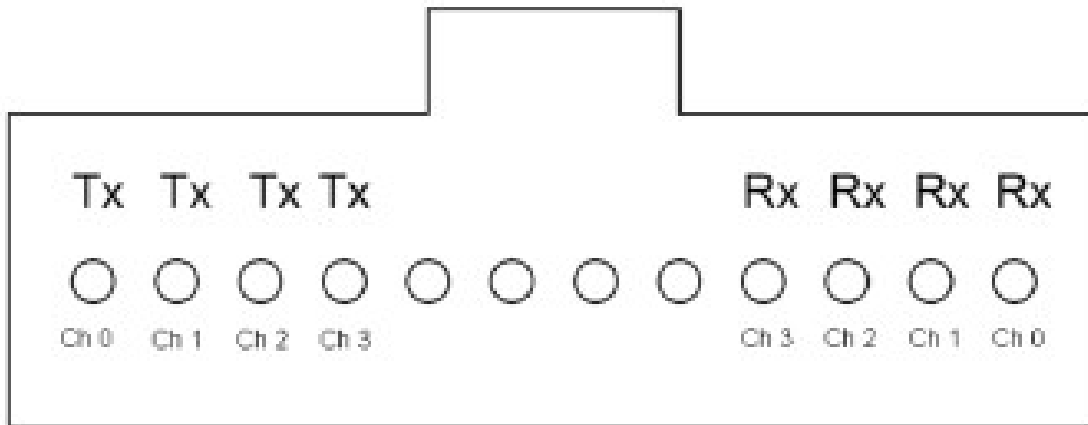

Figure 1 – QSFP+ MSA-compliant 38-pin connector

Pin	Symbol	Name/Description	Note
1	GND	Ground	1
2	Tx2n	Transmitter Inverted Data Input	
3	Tx2p	Transmitter Non-Inverted Data Input	
4	GND	Ground	1
5	Tx4n	Transmitter Inverted Data Input	
6	Tx4p	Transmitter Non-Inverted Data Input	
7	GND	Ground	1
8	ModSelL	Module Select	1
9	ResetL	Module Reset	
10	Vcc Rx	+3.3 V Power supply receiver	
11	SCL	2-wire serial interface clock	
12	SDA	2-wire serial interface data	
13	GND	Ground	1
14	Rx3p	Receiver Non-Inverted Data Output	
15	Rx3n	Receiver Inverted Data Output	
16	GND	Ground	1
17	Rx1p	Receiver Non-Inverted Data Output	
18	Rx1n	Receiver Inverted Data Output	
19	GND	Ground	1
20	GND	Ground	1

21	Rx2n	Receiver Inverted Data Output	
22	Rx2p	Receiver Non-Inverted Data Output	Non-
23	GND	Ground	1
24	Rx4n	Receiver Inverted Data Output	
25	Rx4p	Receiver Non-Inverted Data Output	
26	GND	Ground	1
27	ModPrsL	Module Present	
28	IntL	Interrupt	
29	Vcc Tx	+3.3 V Power supply transmitter	
30	Vcc1	+3.3 V Power Supply	
31	LPMODE	Low Power Mode	
32	GND	Ground	1
33	Tx3p	Transmitter Non-Inverted Data Input	
34	Tx3n	Transmitter Inverted Data Input	
35	GND	Ground	1
36	Tx1p	Transmitter Non-Inverted Data Input	
37	Tx1n	Transmitter Inverted Data Input	
38	GND	Ground	1

Notes: 1. Circuit ground is internally isolated from chassis ground.



40G QSFP+ MPO Optical Lane Assignment (front view of MPO receptacle)

## Power Supply Filtering

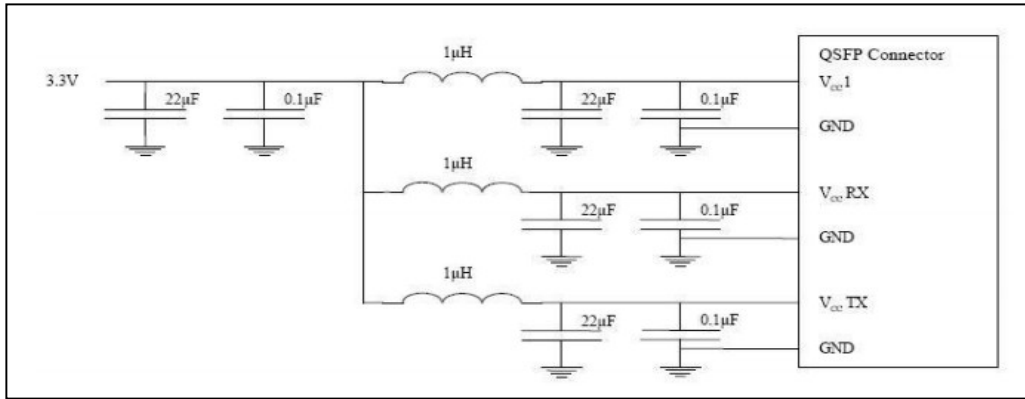

Host Board Power Supply Filtering

## Package Dimensions

### 13. Mechanical Dimensions

↙

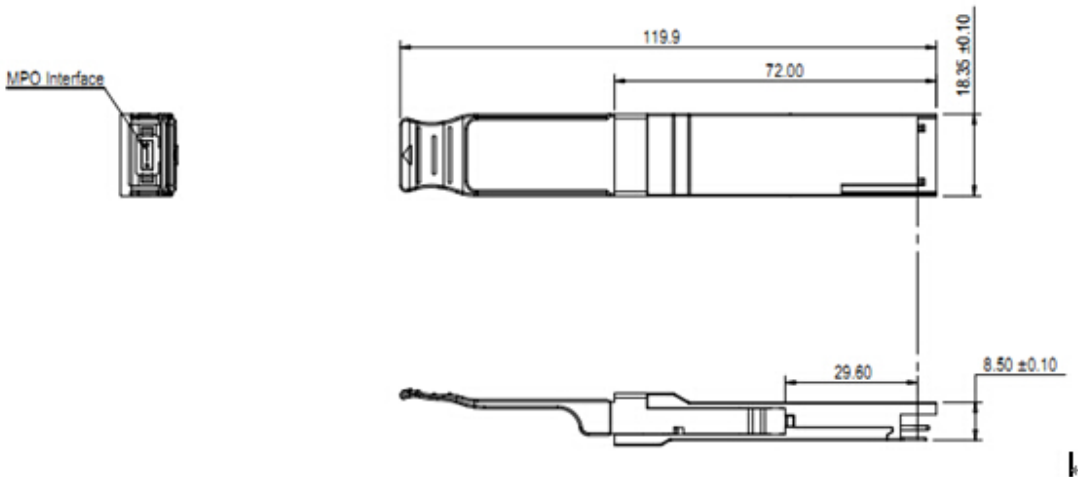





*FH-QSFP4TCDL01*  
*40G QSFP+ 850nm 100m DDMI MPO*

## **For More Information**

FANG HANG TECH LIMITED

Add : 908 Room, Jingyuan Building, No.28 Bulong Rd, Longgang District, Shenzhen. China

Tel: +86-755-89584520

Fax: +86-755-89584520

[sales@fanghangtech.com](mailto:sales@fanghangtech.com)

[www.fanghangtech.com](http://www.fanghangtech.com)